

## 8 Megabit (1Meg x 8 or 512K x 16) UV EPROM and OTP EPROM

### DATA BRIEFING

- FAST ACCESS TIME: 90ns
- WORD-WIDE or BYTE-WIDE CONFIGURABLE
- 8 Megabit MASK ROM COMPATIBLE
- LOW POWER CONSUMPTION
  - Active Current 70mA at 8MHz
  - Standby Current 100µA
- PROGRAMMING VOLTAGE  $12.5V \pm 0.3V$
- PROGRAMMING TIME of AROUND 26sec. (PRESTO III ALGORITHM)

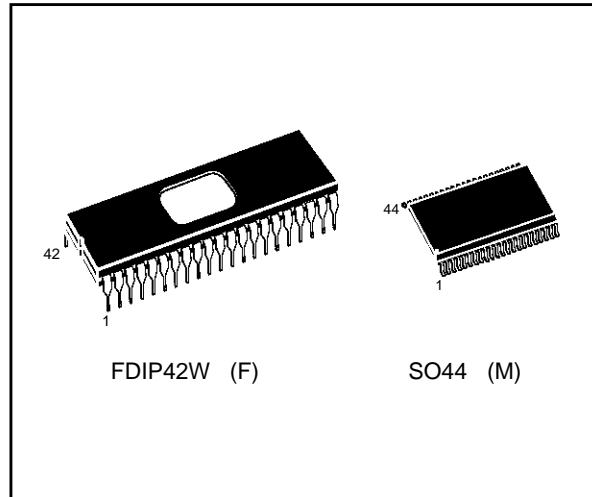

### DESCRIPTION

The M27C800 is an 8 Megabit UV erasable and electrically programmable EPROM ideally suited for microprocessor systems requiring large data or program storage. It is organised as either 1Meg words of 8 bit or 512K words of 16 bit. The pin-out is compatible with a 8 Megabit Mask ROM.

The Window Ceramic Frit-Seal package has a transparent lid which allows the user to expose the chip to ultraviolet light to erase the bit pattern. A new pattern can then be written rapidly to the device by following the programming procedure.

For applications where the content is programmed only one time and erasure is not required, the M27C800 is offered in 44 pin Plastic Small Outline package.

### Logic Diagram

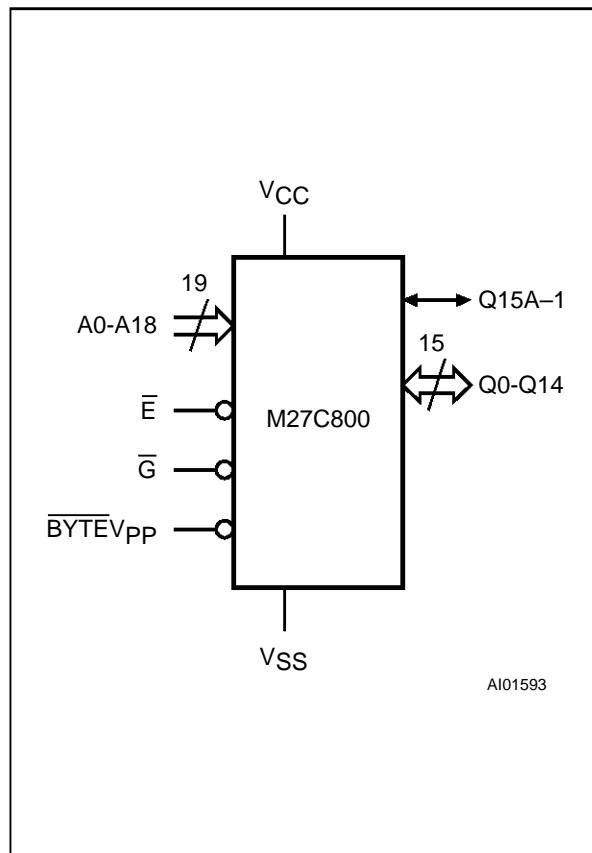

# M27C800

## DIP Pin Connections

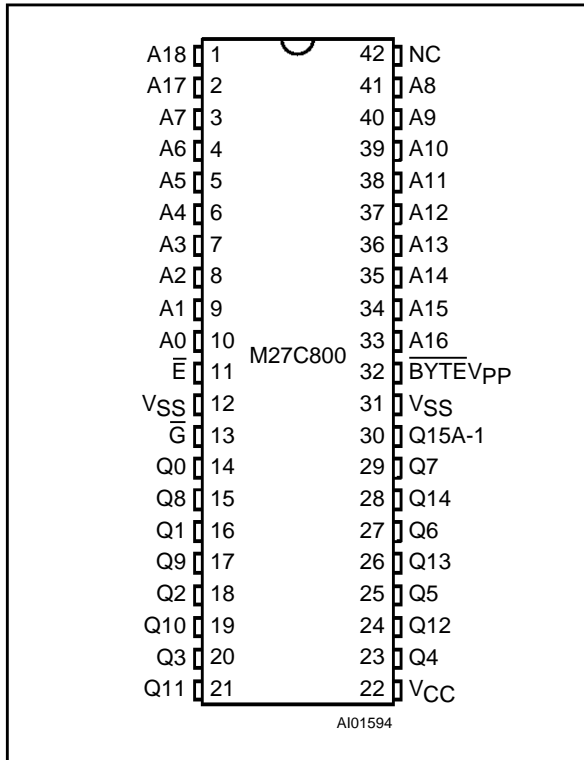

Warning: NC = Not Connected

## SO Pin Connections

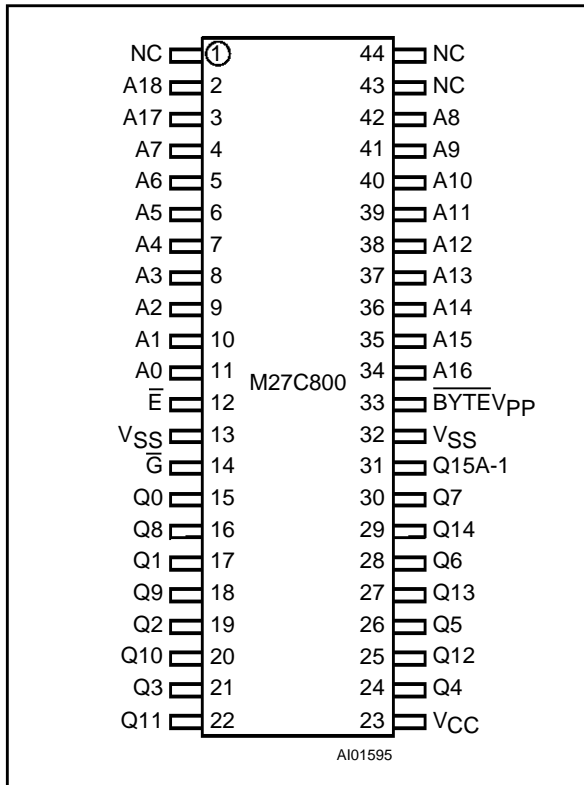

Warning: NC = Not Connected

## Signal Names

A0 - A18	Address Inputs
Q0 - Q7	Data Outputs
Q8 - Q14	Data Outputs
Q15A-1	Data Output / Address Input
$\bar{E}$	Chip Enable
$\bar{G}$	Output Enable
BYTEV <sub>PP</sub>	Byte Mode / Program Supply
V <sub>CC</sub>	Supply Voltage
V <sub>SS</sub>	Ground

## Ordering Information Scheme

For a list of available options refer to the current Memory Shortform catalogue.

For further information on any aspect of this device, please contact the SGS-THOMSON Sales Office nearest to you.

Example: M27C800 -90 M 1

